

Cordless Ultra-Lok[®] Tool



Table of Contents

Warranty, Safety Guidelines, Contents	2
Setup Instructions	3-4
Settings	5
Parts List	6
Troubleshooting	7
Assembly Instructions	8
Clamp Application	
Free-End	9-10
Preformed	11
Maintenance	12-13
Blade Change	14

Warranty

Refer to website for warranty information: <http://www.band-it-idex.com/warranty.html>

NOTE: Any performance data published herein is based on laboratory tests, which cannot duplicate conditions that may be encountered in field installations. Such conditions may vary results substantially from those shown (such as abuse in handling and installation, failure to follow recommended handling and installation practices, abnormal environmental conditions, disregard of operating instructions for BAND-IT tools or non-recommended combinations of BAND-IT products). BAND-IT cannot be responsible for performance characteristics from such variables.

Safety Guidelines

When applying clamps, care should be taken to make certain that fingers are not in the way of the clamp being applied. Tensioning the clamp can be stopped immediately by releasing the trigger. Detailed instructions are in this manual and the operator is advised to read it and become familiar with operating the tool.

IMPORTANT: When clamping a hose end, remember that a tighter clamp keeps the fitting more secure, but excess tension could damage the hose. Fitting stem must have prominent barbs for proper retention inside the hose, but must not be sharp to prevent cutting into the hose. Hose, fitting and clamp must be compatible with each other and the environment used in. If in doubt, consult the hose or fitting manufacturer or call BAND-IT.

Clamping objects other than hose requires similar precautions.

CAUTION: Improperly tightened clamps may result in dangerous hose assemblies, which could cause injuries or property damage.

CAUTION: Abuse or use of a hose outside the manufacturers recommended conditions may cause it to quickly deteriorate and become a safety hazard. This could result in serious injury or property damage. Inspect and test hose assemblies frequently.

Contents



Parts List

- Assembled Tool
- Battery Charger
- Additional Battery Pack
- Syringe Pouch
- Hex Key, 5/32"
- Hex Key, 3/16"
- Manuals, Tool & Drill
- Carrying Case

Setup Instructions



UL4000-B
UL4000-B220
Ultra-Lok® Tool

Warning:

Always wear safety glasses when operating this tool and keep both hands and clothing away from clamp being tensioned. *Squeezing force of 3/4" clamp can reach as high as 2 tons.* Never attempt to clamp objects which can shatter, or otherwise cause bodily harm.

1. Read safety instructions and operator's manual for the Bosch 37618-01 or Bosch GSR 18 VE-2LI cordless Drill. Check to make sure drill is properly set up for use with Band-It Ultra-Lok® tool as follows:
 - Drill spindle has a Clutch (Band-It # M21790) installed in place of the Drill Chuck.
 - See page 5 for recommended Drill speed and torque settings.
2. Charge Drill Battery according to the operator's manual.
3. To mount the Drill onto the Band-It Ultra-Lok® Tool: First, using the two #10-32 x 3/8" screws, tighten the Tool Body Adapter on the Tension Tool with 20–30 in-lbs. Place the Adapter Clamp over the Tool Body Adapter. Orient the Drill Clutch Pin horizontally (see p. 4). Carefully place the Tool Body Adapter over the Drill Torque Dial. If there is any additional resistance, gently rotate the Tension Tool until the Tension Screw engages with the Drill Clutch (see p. 4), and rotate Tension Tool to the desired orientation. Position Tool Body Adapter to butt-up against the shoulder of the handle mounting surface. Slide the Adapter Clamp against this shoulder and fasten to 40–60 in-lbs.
4. This tool was designed for, and can only be used with BAND-IT 1/2" and 3/4" wide Ultra-Lok® clamps. Do not attempt to use on any other type of clamp style. Only use 1/2" wide clamps when the optional 1/2" Shear Plate (BAND-IT # M09387) has been installed in the head in place of the 3/4" Shear Plate.

Use only with BAND-IT 3/4" and 1/2" Ultra-Lok Free-End and Preformed Clamps

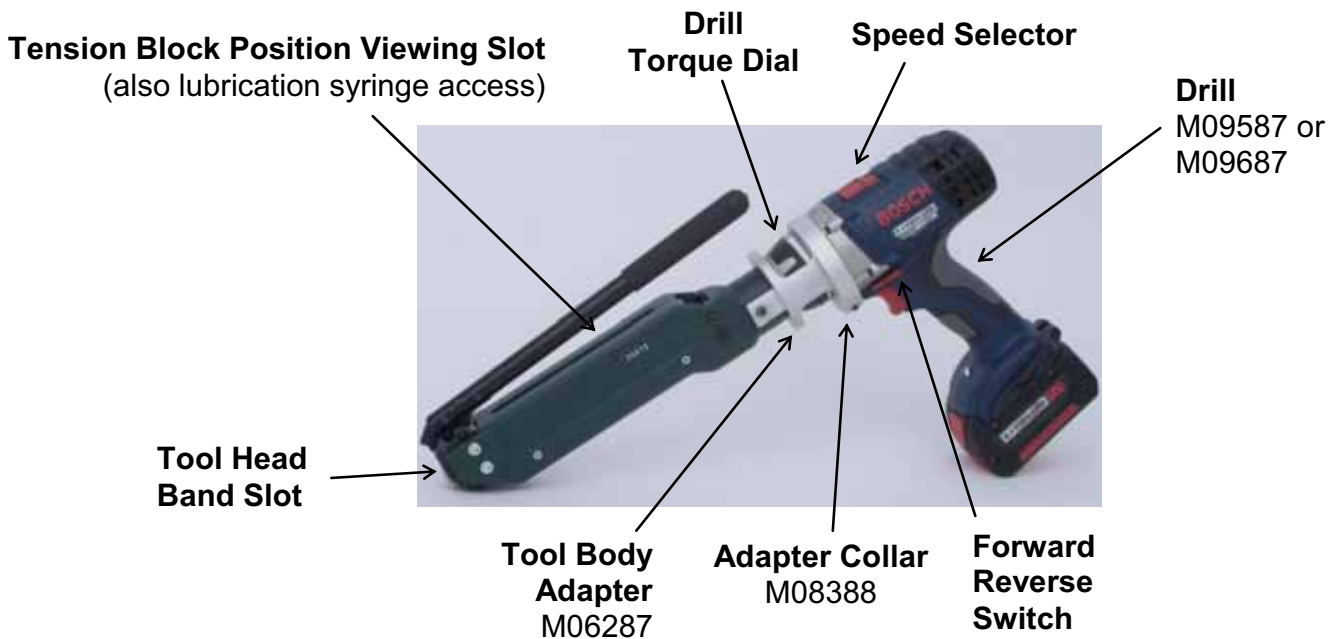

Setup Instructions



UL4000-B
UL4000-B220
Ultra-Lok® Tool

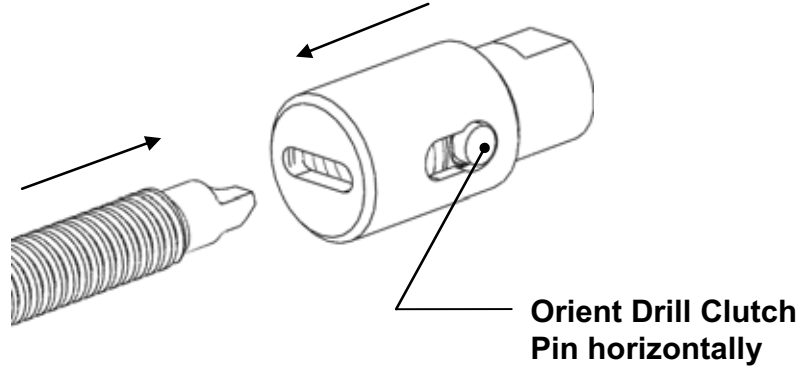

NOTE: Alignment is critical for proper tool function.

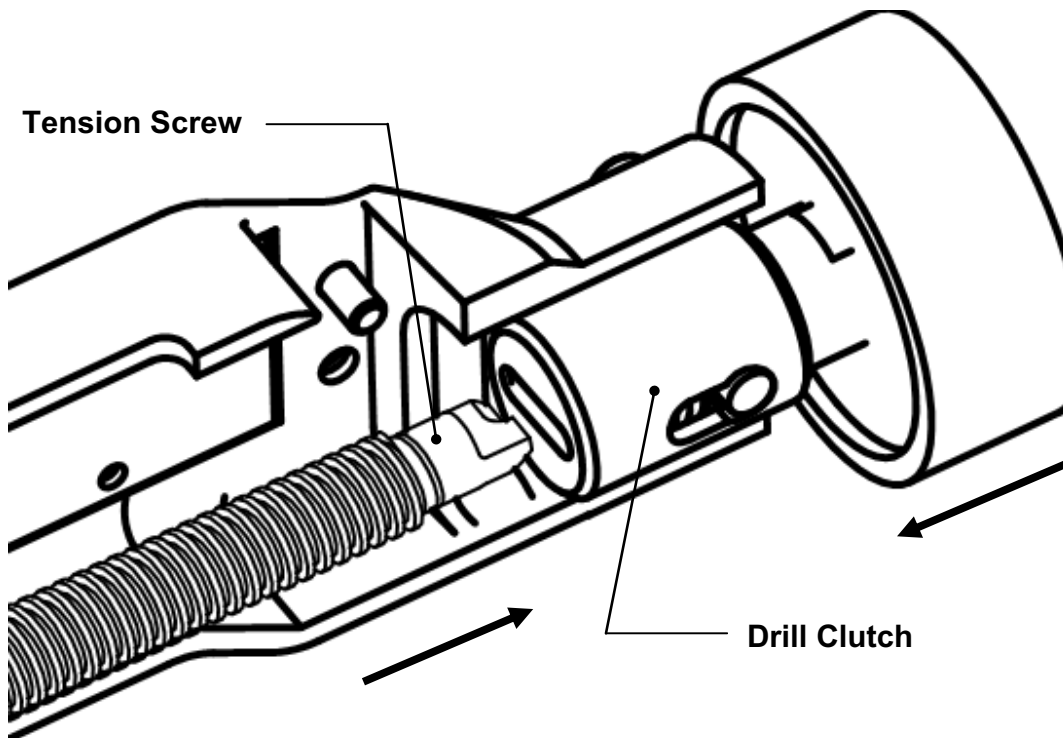

Note: Some components are not visible in this illustration.

Be careful to align the end of the Tension Screw with the slot in the end of the Drill Clutch, as shown above.

Settings



UL4000-B
UL4000-B220
Ultra-Lok[®] Tool

Recommended Drill Torque Dial Settings:

Drill Model	37618-01 / GSR 18 VE-2LI	
Clamp Size	1/2"	3/4"
Single Wrap	11-15	16-20
Double Wrap	16-20	21-25
*Preformed	16-20	21-25

Set Speed Selector to "1"

(If a higher pull-up force is desired, set speed selector to "2". Band-It recommends hearing protection if this setting is used for an extended time.)

NOTE: These torque settings are suggested settings only; individual tools should be adjusted for the clamping application. Inspect lock per instructions on page 9-11.

Important: Changing speed settings will alter tension output. Drill Switch should be depressed fully by the operator to attain correct, and consistent, tension when installing clamps. Tension output may vary from tool to tool, at the same setting, depending on condition and wear of internal components.

Caution: Improperly tightened clamps may result in dangerous assemblies, which could cause injuries or property damage.

Using correctly sized clamps (diameter) will, in most cases, eliminate the need to pull on clamp tail more than once. Tension Block moves approximately 5". On occasion, if needed, large size clamps can be installed by taking several bites (clamp tail feeds out through back of tool). Position of Tension Block, containing gripper, can be monitored through viewing holes just under cut-off handle. The tool features a built-in disengaging mechanism to prevent tension screw from jamming up. Excessive use of this feature will wear the Drill Clutch mechanism and/or Tension Screw out prematurely.

Use of Alternate Drills

CAUTION!

This tool is designed to work mounted to the Bosch 37618-01 or Bosch GSR 18 VE-2LI cordless drill. Use of any other drills in place of this Bosch drill may result in unsatisfactory performance, hazards to the operator and/or the tool, or unsafe clamps. Disregard of this caution voids the warranty of the tool and releases BAND-IT of any and all liabilities arising from such misuses.

Parts List



UL4000-B
UL4000-B220
Ultra-Lok[®] Tool

Notes:

Apply Item 31 (Super Lube) to:
Item 4 (Cut-off Cam)
Item 3 (Cutter Knife) at contact point with item 1 (Tool Head)
Item 26 (Spring) before installation

Apply Item 32 (Grease) to:
Item 7 (Tension Screw) threads and at grooved end
Item 2 (Cutter Blade) counter-bore only, after item 14 (Bearing Tip) has been installed.

Tighten the following:
Item 23 (#10-32 Screws)
to 60 – 70 in-lbs.
Item 22 (1/4-28 Screws)
to 90 – 110 in-lbs.

Adjust Item 24 (Plunger) for
positive detent action when
item 6 (Handle) is actuated.

Item	Part Number	Qty	Description
1	M00587	1	Tool Head, Fin. UL
2	M09787	1	Cutter Blade, UL
3	M08687	1	Cutter Knife, UL
4	M08987	1	Cam, Cut-off, UL
5	M09087	1	Tension Block, Mach., UL
6	UL1219	1	Handle Assembly: Includes Handle, Handle Grip, and Pins
7	M00987	1	Tension Screw, Fin.
8	M08887	1	Gripper, UL
9	M01787	1	Plate, Back, Cast/Fin.
10	M09187	1	Gripper Guide, UL
11	M02387	1	Plate, Release, cast/fin.
12	M00287	1	Roller, Cut-off, Fin.
13	M01388	2	Pin, .187 Dia X 1.50 Long, Fin.
14	M05387	1	Bearing Tip, Fin.
15	M06587	1	Ball, 1/4" Diameter
16	M02287	1	Tip, Load Bearing, Fin.
17	M04387	1	Tripper Bracket, Cast/Fin.
18	M07387	1	Body, Left, Finished, UL
19	M07487	1	Body, Right, Finished, UL
20	M07587	2	Wear Plate, Fin.
21	M05787	2	Screw, Socket Head Cap, 1/4 X 1"
22	J67287	4	Screw, Socket Head Cap, 1/4 X 1/2"
23	M06187	4	Screw, Socket Head Cap, #10-32 X 3/8"
24	M02487	2	Screw, Spring Plunger, 1/4-20
25	A33887	1	Spring, Compression, .180 X .813 Long
26	A53587	2	Spring, Compression, .300 X 1.00 Long
27	M01487	1	Pin, Dowel, 1/4 Dia X 1.50 Long
28	M08187	4	Washer, .128 ID X .238 OD
29	M08087	4	Rivet, Blind, .125 X .328 Long
30	M07987	2	Threaded Insert, #10-32
31	I16387*	.07	Lubricant, Super Lube w/ Teflon (cc)
32	C23199	1	Lubricant, Moly, Syringe
33	M09887	1	Shear Plate, 3/4", UL
34	M09387	1	Shear Plate, UL, 1/2" (Optional)

* Permatex P/N: 82325 or Equivalent

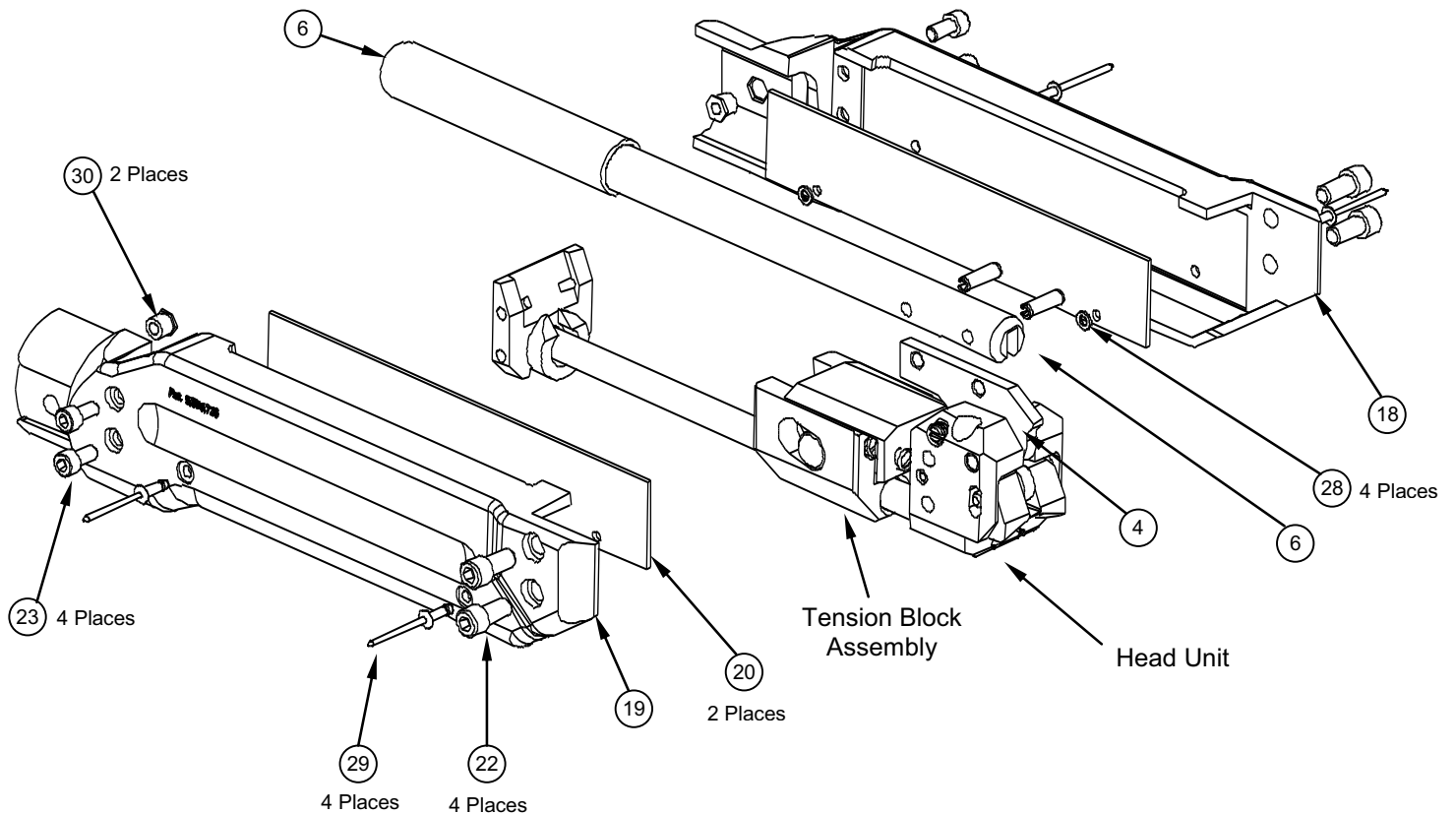

See page 6 for parts list

Trouble-Shooting

1. **Lock slips down in buckle:** Tighten blade mounting screws. If lock on clamp is still not adequate, reduce tension on tool by setting torque setting on the Drill Dial to a lower number.
2. **Drill clutch releases prematurely:** Make sure Tool is fully seated on Drill (per page 4). If problem persists, contact BAND-IT technical support.

Note: To mitigate Drill Clutch wear, do not over-use the Drill Clutch. When tensioning a clamp, let the Drill Switch go as Tension Block nears its end of travel. Reverse drill and send Tension Block all the way forward for a second pull on the band.

Assembly Instructions



UL4000-B
 UL4000-B220
 Ultra-Lok® Tool

Tension Gripper Assembly

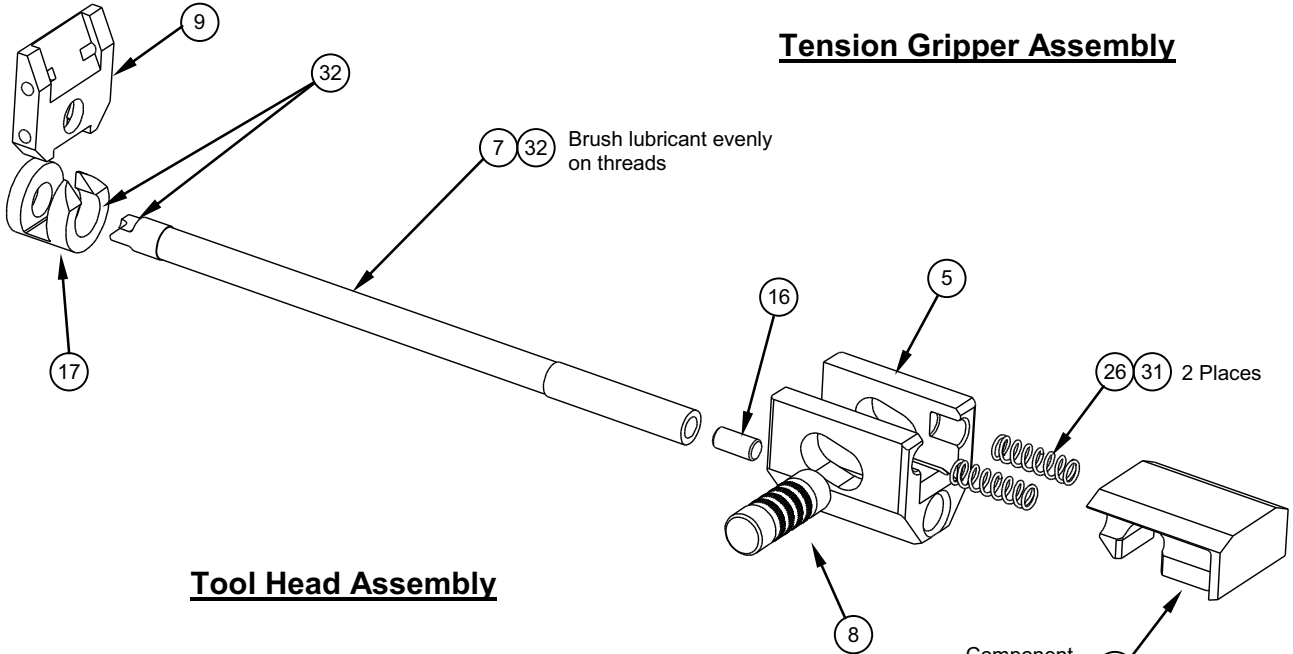

Tool Head Assembly

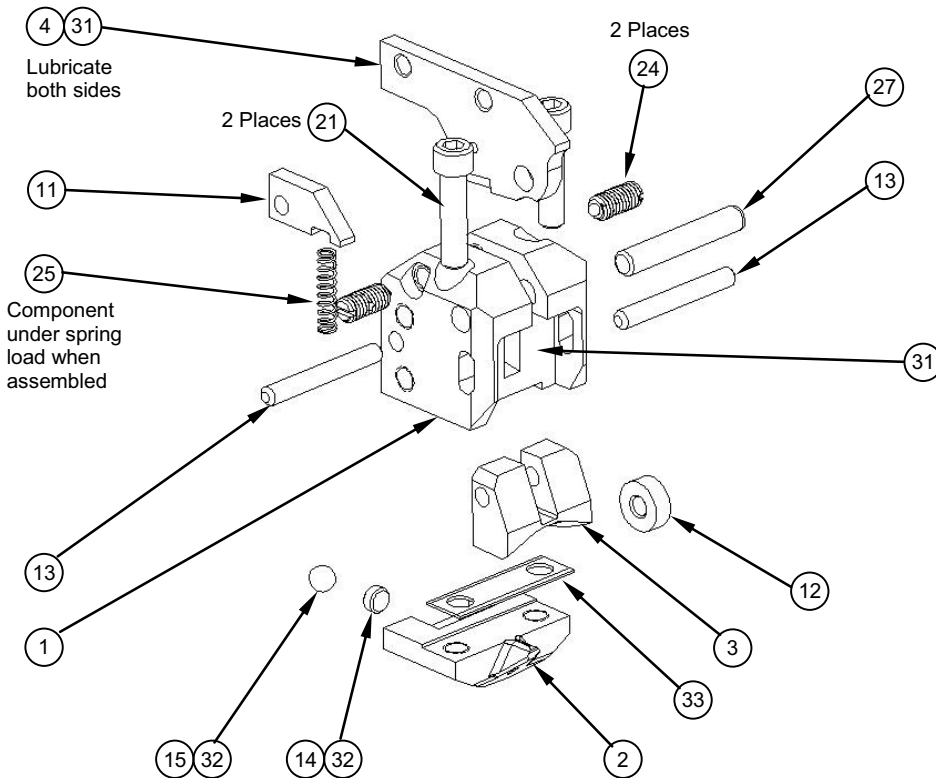

* M09387 (Optional)
 1/2" Shear Plate Insert
 can be substituted for
 M09887

See page 6 for parts list

Clamp Application Free-End Clamps



UL4000-B
UL4000-B220
Ultra-Lok® Tool

Warning: Always wear safety glasses when operating tool.

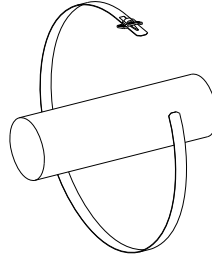
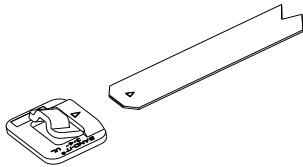

1. Break off an Ultra-Lok® Free-End tie from the roll. Slide the buckle onto band with indented arrows pointing in same direction and same side up. Slide buckle all the way onto band until it comes to a stop between the two buckle dimples at opposite end of tie.

2. Wrap tie around object to be clamped. Insert the tie through buckle once for single-wrap or twice for double-wrap. Double-wrapped clamps have more than 3 times the loop-tensile strength.

3. If desired, you may preform a clamp in the same fashion as step 2, or use a preformed clamp in place of a Free-End

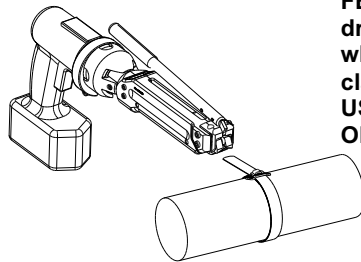
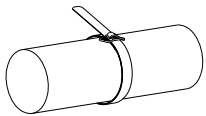

DO NOT FEATHER the drill's TRIGGER when tensioning a clamp. USE FULL SPEED OF TOOL

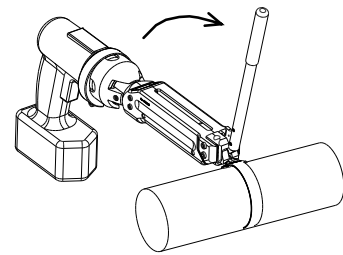

Push all the way forward to a solid stop

4. Position the tie on the object you are clamping. Pull the wrapped tie hand-tight. Slightly bend the tail up to keep the clamp in place

5. Actuate Drill until Tension Block is all the way forward against the tool body. Set Drill to clock-wise rotation. With cut-off handle down as shown, insert clamp tail into tool head slot. Actuate Drill until Drill's built-in clutch disengages. If Tension Block comes near its end of travel, release actuator switch and reverse Drill to pull more on clamp tail. Excessive use of disengaging Drill Clutch indicated by a loud ratcheting sound leads to premature wear of tension screw.

6. Do not force the tool against the clamp; it may result in a folded clamp tail.
7. Pull the cut-off handle forward to cut tail off and form a lock, then return handle to the down position. Reverse drill and feed clamp tail out of tool.
8. Tap down buckle shroud to complete clamp. Tool is ready for next clamp.

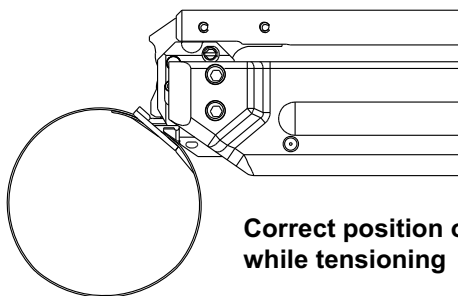

Correct position of tool while tensioning

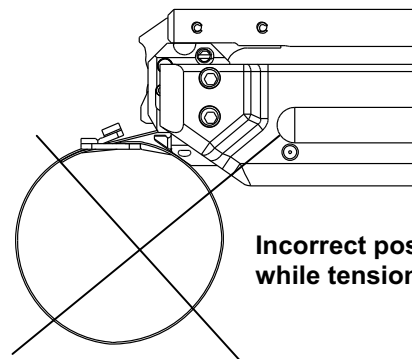

Incorrect position of tool while tensioning

Clamp Application Free-End Clamps



UL4000-B
UL4000-B220
Ultra-Lok® Tool

Inspect buckle on completed clamp and tap down buckle shroud.

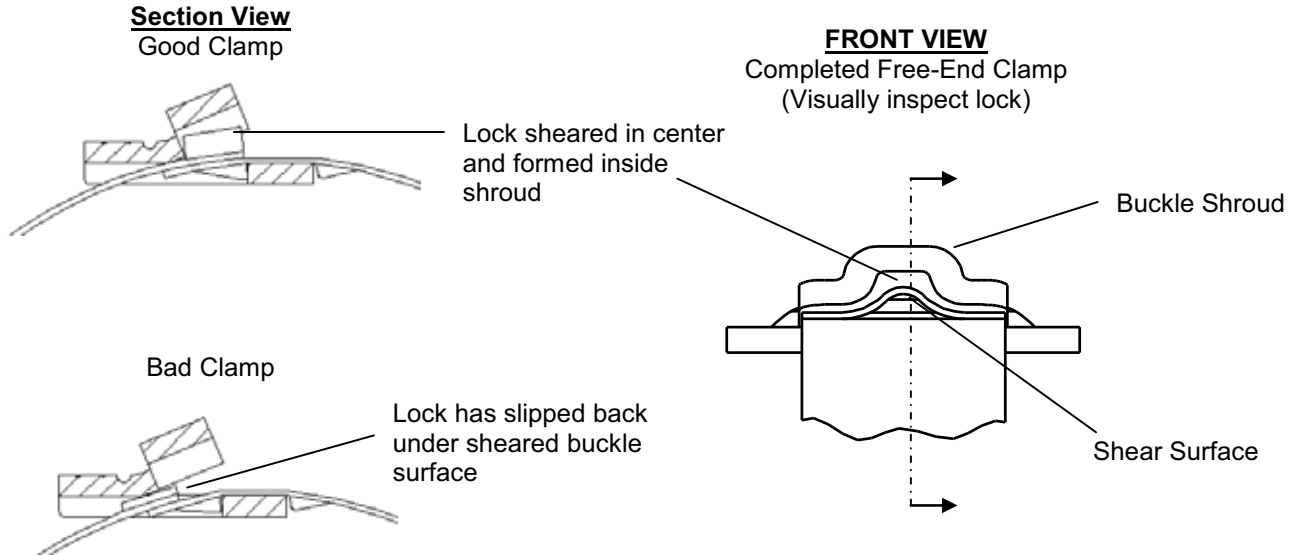

Important: Visually inspect lock formed in band as shown. If lock has slipped under the sheared surface of the buckle, remove clamp and install a new one at reduced tension by lowering the Drill Clutch torque setting.

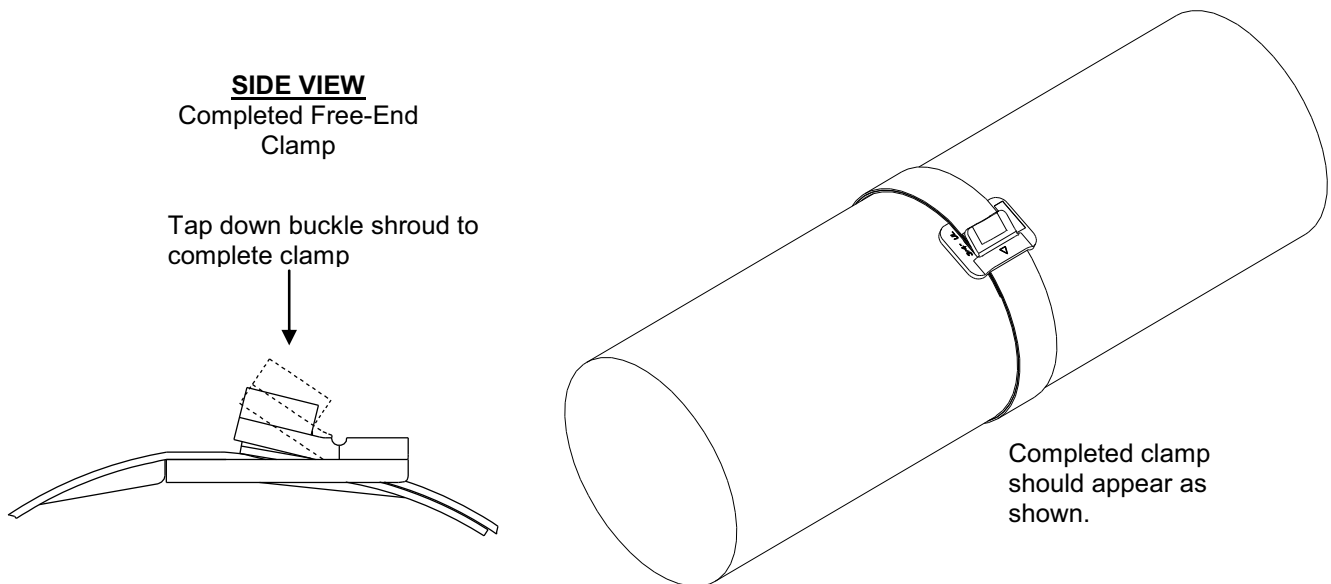

Clamp Application Preformed Clamps



UL4000-B
UL4000-B220
Ultra-Lok[®] Tool

Place clamp in desired position on object to be clamped.
Follow steps 5 and 6 on page 9.
Inspect buckle on completed clamp and tap down buckle shroud as shown below.

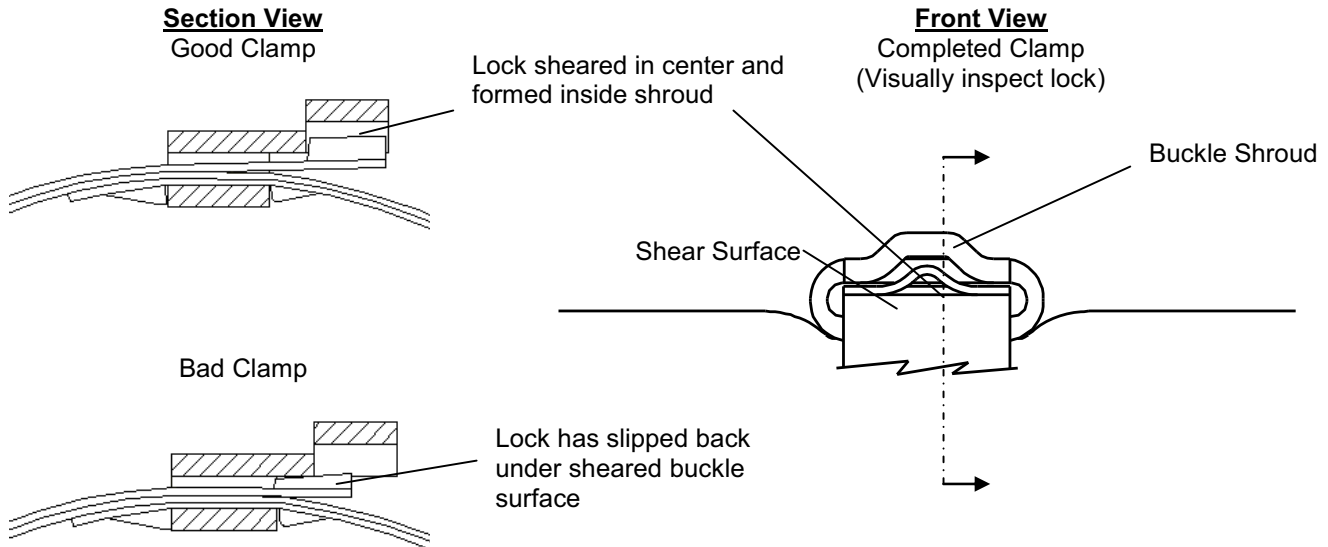

Important: Visually inspect lock formed in band as shown. If lock has slipped under the sheared surface of the buckle, remove clamp and install a new one at reduced tension by lowering the Drill Clutch torque setting.

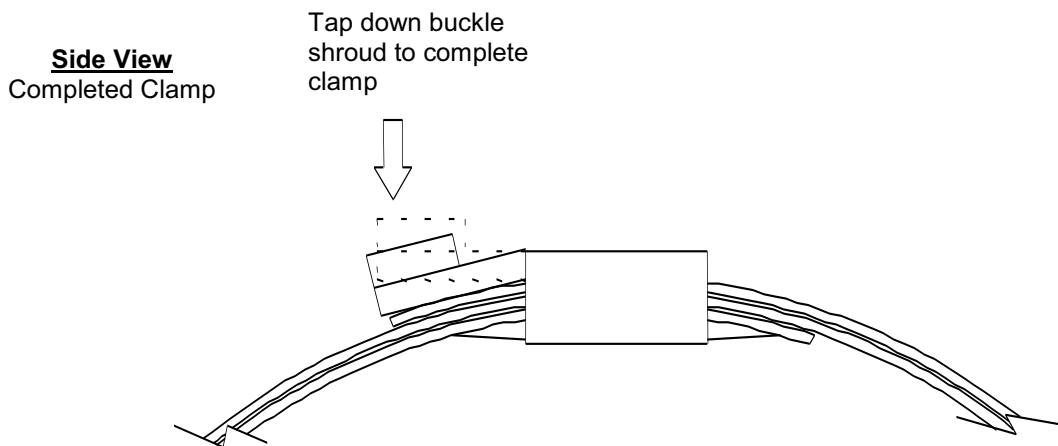

When applying clamps on soft, thick-walled hose, tension clamp then wait a full 30 seconds. Clamps may be re-tensioned by squeezing the Drill Switch on the power unit a second time prior to forming the lock and cutting the excess clamp tail. This allows hose to “settle” under the band of the clamp. This hose material attribute is called Cold Flow. Finally, complete clamp by tapping down the buckle shroud as described above.

Maintenance



UL4000-B
UL4000-B220
Ultra-Lok[®] Tool

1. Approximately every 500 clamps lubricate Tension Screw with molybdenum disulfide lubricant, or equivalent. Make sure Tension Block is all the way forward against the Tool Head. Remove cap from syringe and insert tip of syringe into slot on top of tool body. Press the tip against the Tension Screw just behind the Tension Block and squeeze out approximately 1/2" long bead of lubricant. Remove Syringe, and actuate tool without a clamp a couple of times to spread lubricant evenly on tension screw.

To order more lubricant, specify BAND-IT #C23199

2. Every 500-1000 clamps, depending on torque setting, inspect and repack front bearing with same lubricant. Turn load bearing tip and small bearing tip over for a new bearing surface.

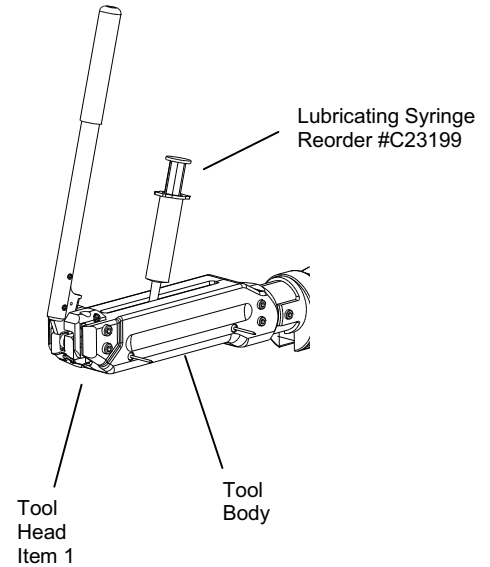

Bearing Detail

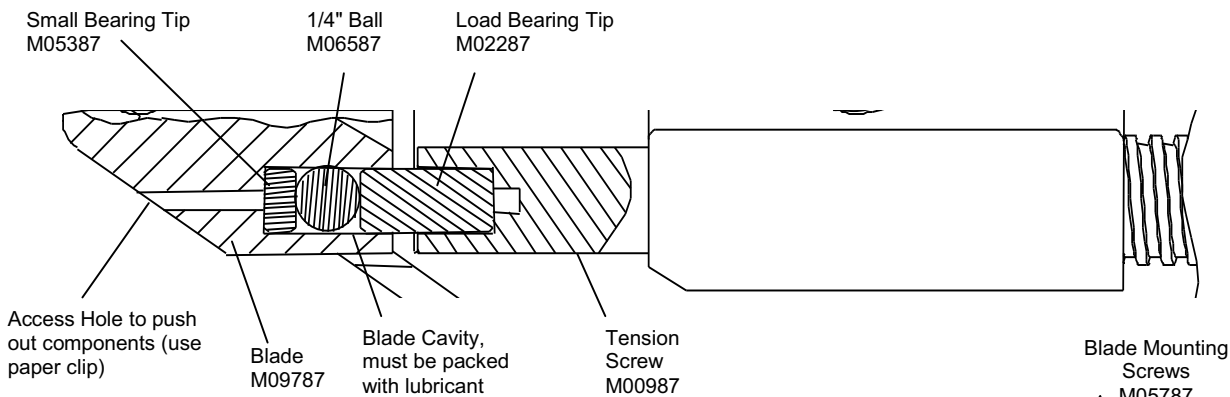

3. To gain access to bearing components: remove blade Mounting Screws (2 places) and slide Blade free. Paper clip may be used to push bearing components out of Blade. Wipe lubricant from components. If ball or bearing tips appears heavily worn, replace with new one. Note: 1/4" ball is made from hard tungsten carbide material, do not replace with regular ball bearing. (Smooth indentation from ball in the bearing tips is normal).

To re-assemble bearing components: wipe blade cavity clean. Push small bearing tip into blade cavity. Apply lubricant to ball and push into Blade cavity and fill remaining space with lubricant. Push load bearing tip firmly into blade cavity, some lubricant will be squeezed out. Re-attach blade to Tool Head, making sure that load bearing tip extends into Tension Screw. While turning Blade Mounting Screws into Blade, push on Blade rear-wards. Tighten screws to approximately 120 in-lbs.

4. When replacing worn Blade follow instructions above to properly re-assemble bearing components.

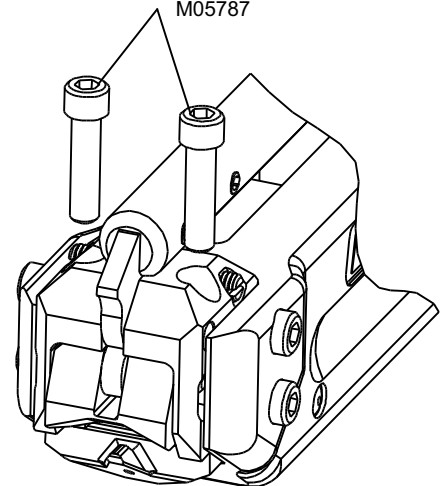

5. To replace Gripper: Make sure Tension Block is all the way forward against the tool head. Remove drill. Remove tool adapter body. Remove one side of the tool body or the other, not both. Slide Gripper out sideways and replace with a new one. Re-attach Tool Body side. **Caution:** Do not push or move Tension Block while Gripper is out of tool.

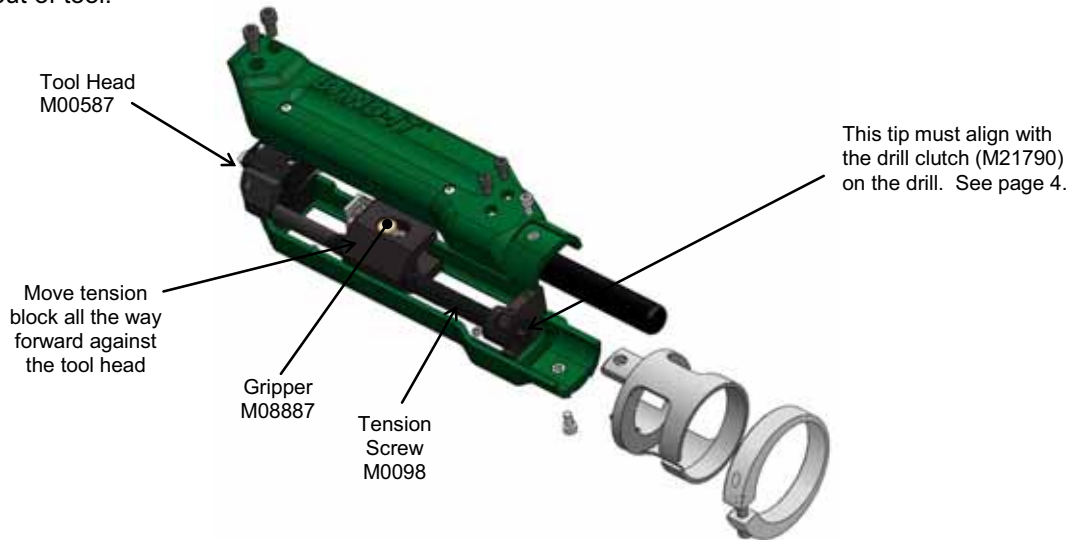

6. To replace Tension Screw: Move Tension Block all the way back (away from Tool Head) using drill in tensioning mode (clock-wise). Remove Ultra-Lok[®] Tool from Drill. Remove the Tool Adapter from the Ultra-Lok[®] Tool. Remove Blade and load bearing tip from Tensioning Screw (see bearing detail). Remove one side of the Tool Body or the other, not both. Grasp the smooth barrel on Tension Screw and pull all the way forward until Tension Block is against the Tool Head. If Tension Screw is stuck, use a punch and tap the center of the screw from the back end of the tool. Turn Tension Screw out of Tension Block. Lubricate new Tension Screw with Molybdenum Disulfide lubricant, or equivalent. Install new Tension Screw in reverse order; making sure that back end of Tension Screw extends well beyond the back end of the Tension Block. Push the assembly all the way back and extend the round portion of the Tension Screw through holes on the tripper bracket and back guide plate. Reinstall Tool Body side. Reinstall Blade and tighten the Blade Mounting Screws approximately 120 in-lbs. Reattach Tool Adapter to Ultra-Lok[®] Tool. Reattach Tool to Drill and drive Tension Block all the way forward.

Note: Drills needing repair must be forwarded to an authorized 'Bosch' repair center in your area. Be sure to remove BAND-IT drill clutch (M21790) from drill.

Bosch Drill is covered solely by the Bosch warranty as described in the Bosch literature. BAND-IT does not extend any warranty of any kind to the drill.

Blade Change Optional 1/2" Tool



UL4000-B
UL4000-B220
Ultra-Lok® Tool

To change out the tool to the 1/2" version, the following steps should be followed.

***NOTE: Do not attempt to use 1/2" clamps with 3/4" head. (Shear Plate change-out: 3-5 minutes)**

1. Prior to separation from power drill, back off Tension Block assembly 1/2" from head unit. See page 7.
2. Detach Tension Body from the Drill by loosening the single tensioning bolt on the aluminum collar and separating the two sections.
3. Remove the Blade from head by removing the two Cap Screws (M05787) from the top of the Head. It is not necessary to remove entire head from tool in order to remove blade. (Figure 1) Remove the 3/4" shear plate from the blade.
4. Align the 1/2" Shear Plate (M09387) with the Blade (M09787) so that the guide is facing up. Incorrect placement will not allow bands to be inserted into the Tool. (Figure 1)
Note: To convert Tool back to 3/4", replace 1/2" Shear Plate with 3/4" Shear Plate (M09887) and follow same instructions. Be sure to retain unused Shear Plate for later use.
5. Attach the Blade and 1/2" Shear Plate onto Head using the two previously removed Cap Screws. These Cap Screws must be tight to assure proper cut-off of clamp tails.
6. Re-attach Drill to Tension Body making sure the Drill and Tension Body are properly aligned, and tighten the single Blade Cap Screw located on the Adapter Collar.
7. **These tools are not designed to work with traditional band and buckle designs. BAND-IT Ultra-Lok® clamps must be used.**

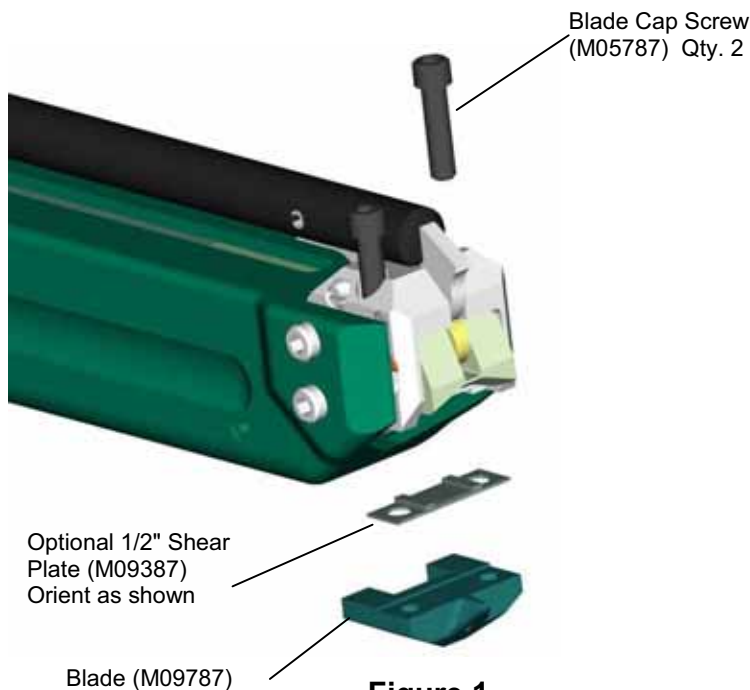

Figure 1

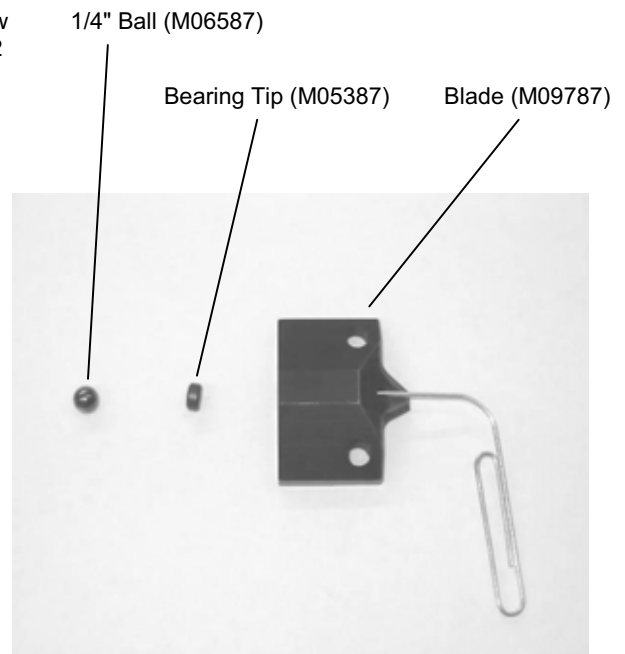

Figure 2